

A Series

CARTRIDGE FILTER HOUSINGS

Carbon or Stainless Steel construction with a wide range of features and options

INTRODUCTION

All Jonell Systems A series (formerly Nowata) cartridge filter housings are designed for efficient liquid filtration and can be customized with a wide range of features and options. Flexibility in the exact design of your filter is an important advantage of our filter housings. We will help you design a filter to fit the exact configuration and needs of your operating environment. The housing's robust construction gives extended life in the toughest conditions. The epoxy coated AS Series option has been the industry standard for produced water and brine filtration for many years.

These filter housings provide operators with highly efficient liquid filtration, matched to their specific operating requirements. Flow rates, operating pressures and temperatures, plus the fluid being filtered are all taken into consideration when selecting the right filter for the job.

A series cartridge filter housings can be designed for many working pressures, flow rates, number of cartridges, mounting hardware, connection location, ASME code construction and more. These choices allow us to create a filtration system that is matched to your exact operating conditions.

Note: some customization may change the model number designation to B, D or F series.

FEATURES

- Sizes from 4 to 81 cartridges
- 200 to 1440 psi working pressure
- Aqueous flow rates to 648 gpm
- Bolted closure for safe, fast cartridge replacement
- Multiple O-ring closure seals available
- ASME code construction available

HOUSING MATERIAL CHOICES

- Standard carbon steel construction
- Carbon steel with stainless steel trim & epoxy lining
- Stainless steel wetted construction



DIMENSIONAL INFORMATION

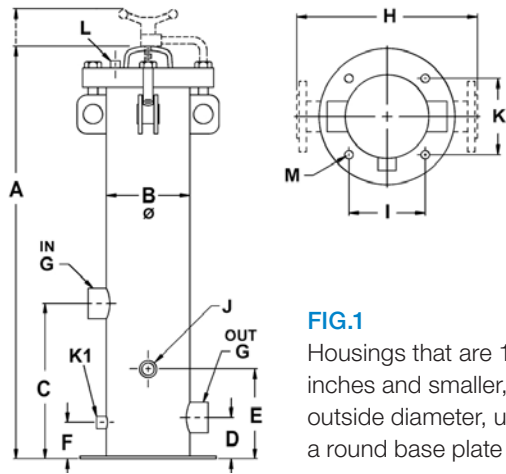

FIG. 1
Housings that are 12³/₄ inches and smaller, outside diameter, utilize a round base plate

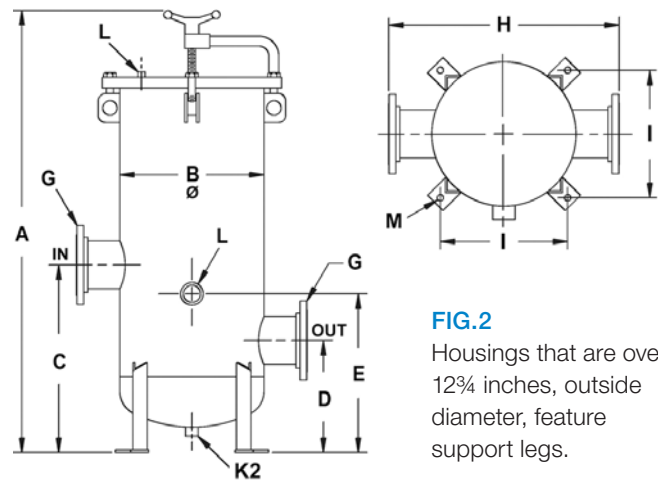

FIG. 2
Housings that are over 12³/₄ inches, outside diameter, feature support legs.

Model	Max. Pressure (psi)	No. of Cartridges	No. of Cartridge posts	Weight (lbs)	A	B	C	D	E	F	G	J	K
A4	200	4	2	160	34	6 ⁵ / ₈	12	4 ¹ / ₄	8	3 ¹ / ₄	2	14 ⁵ / ₈	6 ¹ / ₂
AS4	300			34	8			3 ¹ / ₄	16 ⁵ / ₈				
U4	740			39	8 ¹ / ₄			3 ¹ / ₄	16 ⁵ / ₈				
	1440			39	8 ¹ / ₂			3 ³ / ₄	16 ⁵ / ₈				
A6	200	6	2	190	45	6 ⁵ / ₈	12	4 ¹ / ₄	8	3 ¹ / ₄	2	14 ⁵ / ₈	6 ¹ / ₂
AS6	300			45	8			3 ¹ / ₄	16 ⁵ / ₈				
U6	740			49	8 ¹ / ₄			3 ¹ / ₄	16 ⁵ / ₈				
	1440			49	8 ¹ / ₂			3 ³ / ₄	16 ⁵ / ₈				
A8	200	8	4	190	36	8 ⁵ / ₈	16	4 ¹ / ₄	8	3 ¹ / ₄	2	16 ⁵ / ₈	7 ⁷ / ₈
AS8	300			36	9 ¹ / ₂			3 ¹ / ₄	18 ⁵ / ₈				
U8	740			41	10			3 ¹ / ₂	18 ⁵ / ₈				
	1440			41	10			4	18 ⁵ / ₈				
A12	200	12	4	220	47	8 ⁵ / ₈	16	5	9 ¹ / ₂	3 ¹ / ₄	3	16 ⁵ / ₈	7 ⁷ / ₈
AS12	300			47	9 ¹ / ₂			3 ¹ / ₄	18 ⁵ / ₈				
U12	740			51	9 ¹ / ₂			3 ¹ / ₂	18 ⁵ / ₈				
	1440			51	9 ¹ / ₂			4	18 ⁵ / ₈				
A21	200	21	7	280	51	10 ⁵ / ₈	16	5	10	3 ¹ / ₄	3	18 ³ / ₄	9 ³ / ₈
AS21	300			51	10			3 ¹ / ₄	20 ³ / ₄				
U21	740			53	10 ¹ / ₂			3 ³ / ₄	20 ³ / ₄				
	1440			53	10 ¹ / ₂			4 ¹ / ₄	20 ³ / ₄				
A30	200	30	10	380	52	12 ⁵ / ₈	18	6	11 ¹ / ₂	3 ¹ / ₄	4	24 ³ / ₄	11 ¹ / ₂
AS30	300			52	11 ¹ / ₂			3 ³ / ₄	24 ³ / ₄				
U30	740			53	11 ¹ / ₂			4	24 ³ / ₄				
	1440			57	12 ¹ / ₂			4 ¹ / ₂	24 ³ / ₄				
A48	200	48	16	510	64	16	27 ¹ / ₂	17 ¹ / ₄	22 ³ / ₄	N/A	4	28	14 ⁷ / ₈
AS48	300			66	17 ¹ / ₄			22 ³ / ₄	28				
U48	740			70	17 ¹ / ₄			23	28				
	1440			70	18 ¹ / ₂			22 ³ / ₄	28				
A60	200	60	20	700	70	18	29 ¹ / ₂	18 ¹ / ₂	25 ¹ / ₂	N/A	6	30	16 ¹ / ₄
AS60	300			70	19			25 ¹ / ₂	30				
U60	740			70	19			25 ¹ / ₂	30				
	1440			70	19			25 ¹ / ₂	30				
A81	200	81	27	850	67	20	29 ¹ / ₂	18 ¹ / ₂	25 ¹ / ₂	N/A	6	32	17 ⁵ / ₈
AS81	300			70	19			25 ¹ / ₂	32				
U81	740			70	19			25 ¹ / ₂	32				
	1440			74	32 ¹ / ₂			20	32				

Dimensions in inches unless otherwise noted. Specifications are for reference only and subject to change without notice.

NOTES: A = Overall height, also see (4)
 B = Vessel outside diameter
 C = Height to inlet centerline
 D = Height to output centerline
 E = Height to upper chamber drain centerline
 F = Height to vessel drain centerline (FIG. 1 only)
 G = Inlet & Outlet connection size,
 2" and 3" internal pipe thread standard;
 4" and 6" RF ANSI Flanges standard

H = Flanged connection face to face-inlet & outlet
 I = Mounting hole spacing
 J = Internal pipe thread upper chamber drain size
 (FIG. 1 only: Under 9" O.D. = 1", Over 9" O.D = 2")
 K1 = Internal pipe thread vessel drain size (1/2")
 K2 = Internal pipe thread vessel drain size (1")
 L = Internal pipe thread vent size
 M = Mounting holes (4 each) diameter (7/8")

1 = Shown are the first few characters of part numbers
 2 = Maximum allowable non-shock pressure
 3 = Number of 9-3/4" or 10" length cartridges, single length equivalents
 4 = Davit arm provided as standard on all models except the 200 and 300 psi models in the 4, 6, 8 and 12 cartridge sizes

STANDARD CONSTRUCTION NOTES

Standard A Series Construction

A series models are designed for applications involving fresh water and non-corrosive fluids.

They are constructed of all welded carbon steel with internal cartridge supports and retainers of Brass. Larger models come standard with closure lifting davits for easy cartridge removal. 3" or smaller inlet and outlet connections are FNPT internal pipe thread. The 4" and larger sizes are provided with ANSI flanges.

Internal pipe threaded vessel drain, backwash drain and vent are standard, with the size depending on vessel diameter.

U Series Construction Feature

The U series feature is designed for applications requiring the increased corrosion resistance and fluid compatibility of stainless steel. All wetted surfaces, including the cartridge supports and the retainers, are 316 stainless steel. The top closure is constructed of high-strength carbon steel, with a stainless steel liner plate.

S Series Construction Feature

The S feature provides epoxy lined carbon steel construction, with 316 stainless steel in the uncoated area of the closure o-ring seal.

Internal pipe thread, vent and drain connections are also made of 316 stainless steel. Brass internal cartridge fittings are furnished as standard, other materials are available. Although exposed areas are made of 316 stainless steel, all wetted carbon steel surfaces are coated with epoxy. Care should be taken to use the S feature housings with fluids that do not vigorously attack plain steel.

Standard Construction for Glycol Filtration

A series models are especially suited for removing solids from triethylene glycol in natural gas dehydrators. Since Brass cannot be used with glycol, plated carbon steel internals are required. Solids in the glycol stream can damage pumps and plug spray nozzles. Most applications require filtration in the 25 to 50 micron range, to provide the protection needed.

Working Pressure Ranges

A series housings are available in the following maximum allowable non-shock working pressure ratings:
200 psi, 300 psi, 740 psi, and 1440 psi.

OPTIONAL CONSTRUCTION NOTES

Seal Material

The standard Buna o-ring operates at up to 250 °F. Viton seals are available for up to 450 °F service. Other o-ring materials, such as Teflon encapsulated silicone, and ethylene propylene are also available.

Connections

Customized inlet and outlet connection sizes and locations are available on all filter housings. All units are available with optional external pipe thread connections or ANSI flanges. Internal pipe threaded drains and vent are provided as standard. Connections are also available in flanged or external pipe thread type, or in non-standard sizes. Special purpose connections, such as relief valve fittings and pressure taps, are also available. Non-standard connections location, unusual mounting heights or dimensions are also available.

Internal Materials

Standard brass and optional plated carbon steel internals are stocked at the factory. 316 stainless steel is standard for the U series and optional on the A series.

Horizontal Housings

Our rigid cartridge support and seal system is ideally suited for the horizontal configuration of the A series housings. This is especially important when overhead clearance, or other unique operating considerations preclude the usual vertical installation of the housings.

Extra Length Housings and Cartridges

When extra dirt holding capacity is needed, an extra length housing can be built to hold our 40" length cartridges. This offers the advantage of a 33% increase in cartridge life, for little extra cost.

ASME Code Construction

A series filters are designed in accordance with the Pressure Vessel Code of the American Society of Mechanical Engineers. When required, each unit can be stamped with the appropriate ASME code denoting fabrication and testing performed by specific procedures.

Accessories

Several items are available to monitor or control filter operation. Ask us about accessory features for your filtration system.

